

# Cat® DE110 GC

## Diesel Generator Sets



Standby: 50 Hz & 60 Hz



Image shown might not reflect actual configuration.

Engine Model	Cat® C4.4 Inline 4-stroke Diesel
Bore x Stroke	105.0 mm x 127.0 mm (4.1 in x 5.0 in)
Displacement	4.4 L (268.5 in <sup>3</sup> )
Compression Ratio	18.23:1
Aspiration	Turbocharged Air To Air Charge Cooled
Fuel Injection System	Inline
Governor	Mechanical

Model	Standby		Emission Strategy
	50 Hz kVA (ekW)	60 Hz kVA (ekW)	
DE110 GC	110.0 (88.0)	125.0 (100.0)	Low BSFC

## PACKAGE PERFORMANCE

Performance	Standby	
	50 Hz	60 Hz
Genset power rating	110.0 kVA	125.0 kVA
Genset power rating with fan @ 0.8 power factor	88.0 kW	100.0 kW
Emissions	Low BSFC	
Performance number	P2634B	P2634A
<b>Fuel Consumption</b>		
Fuel tank capacity, litres (US gal)	166 (43.8)	
100% load with fan, L/hr (gal/hr)	24.4 (6.4)	29.2 (7.7)
75% load with fan, L/hr (gal/hr)	18.4 (4.8)	21.9 (5.8)
50% load with fan, L/hr (gal/hr)	12.8 (3.4)	15.4 (4.1)
<b>Cooling System<sup>1</sup></b>		
Radiator air flow, m <sup>3</sup> /min (cfm)	187.8 (6632)	244.2 (8624)
Total coolant capacity, L (gal)	17.5 (4.6)	
<b>Inlet Air</b>		
Max. combustion air intake restriction, kPa (in H <sub>2</sub> O)	8.0 (32.1)	
Combustion air inlet flow rate, m <sup>3</sup> /min (cfm)	6.3 (221)	7.8 (275)
<b>Exhaust System</b>		
Exhaust stack gas temperature, °C (°F)	543 (1009)	574 (1065)
Exhaust gas flow rate, m <sup>3</sup> /min (cfm)	16.3 (576)	20.4 (720)
Exhaust system backpressure (maximum allowable), kPa (in. water)	18.0 (5.3)	15.0 (4.4)
<b>Heat Rejection</b>		
Heat rejection to jacket water, kW (Btu/min)	50.7 (2883)	64.0 (3640)
Heat rejection to alternator, kW (Btu/min)	7.8 (444)	8.3 (472)
Heat rejection to atmosphere from engine, kW (Btu/min)	7.5 (427)	9.4 (535)
Heat rejection to exhaust (total) kW (Btu/min)	78.9 (3358)	99.7 (4041)

# DE110 GC Diesel Generator Sets Electric Power



Alternator <sup>2</sup>	50 Hz			60 Hz				
	Voltages	380	415	400	480	440	220	380
Motor starting capability @ 30% Voltage Dip, skVA	189	225	209	251	210	210	157	188
Current, amps	167.1	153	158.8	150.4	164	328	167.4	283.2
Temperature Rise, °C	163/27	163/27	163/27	150/40	163/27	163/27	163/27	163/27
Frame Size	A2153L4							
Excitation	S.E							

## WEIGHTS & DIMENSIONS

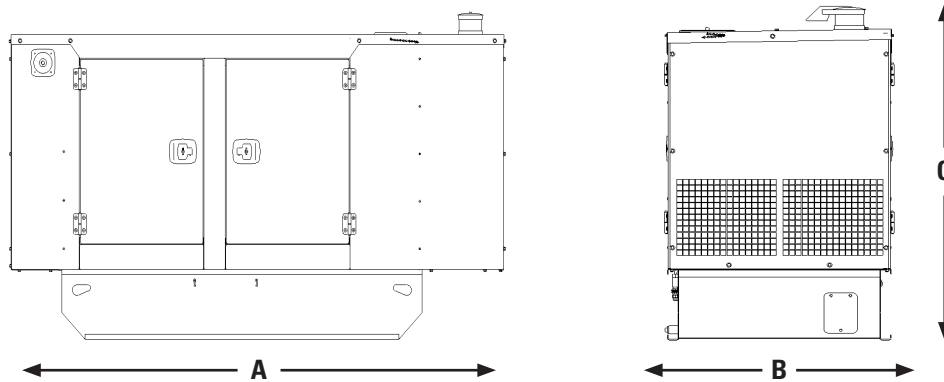

**Note:** General configuration not to be used for installation. See general dimension drawings for detail.

Dim "A" mm (in)	Dim "B" mm (in)	Dim "C" mm (in)	Dry Weight kg (lb)
2745 (108.5)	999 (39.3)	1476 (58.1)	1330 (2932.1)

<sup>#</sup>Weight includes standard generator, Enclosure and Integral Tank base

### APPLICABLE CODES AND STANDARDS:

AS1359, NFPA37, NFPA70, NFPA99, NFPA110, IEC 60034-1, ISO 3046, ISO 8528, 2006/95/EC, 2006/42/EC, 2004/108/EC. Note: Codes may not be available in all model configurations. Please consult your local Cat Dealer representative for availability.

**STANDBY:** Output available with varying load for the duration of the interruption of the normal source power. Average power output is 70% of the standby power rating. Typical operation is 200 hours per year, with maximum expected usage of 500 hours per year.

**RATINGS:** Ratings are based on SAE J1349 standard conditions. These ratings also apply at ISO 3046 standard conditions.

### DEFINITIONS AND CONDITIONS

- <sup>1</sup> For ambient and altitude capabilities consult your Cat dealer. Air flow restriction (system) is added to existing restriction from factory.
- <sup>2</sup> Generator temperature rise is based on a 27°C ambient per NEMA MG1-32.

**LET'S DO THE WORK.™**

[www.cat.com/electricpower](http://www.cat.com/electricpower)

©2020 Caterpillar  
All rights reserved.

Materials and specifications are subject to change without notice.

The International System of Units (SI) is used in this publication. CAT, CATERPILLAR, LET'S DO THE WORK, their respective logos, "Caterpillar Corporate Yellow" the "Power Edge" and Cat "Modern Hex" trade dress as well as corporate and product identity used herein, are trademarks of Caterpillar and may not be used without permission.