

Standby & Prime: 50Hz



Image shown might not reflect actual configuration

Engine Model	Cat® C18 ATAAC™ In-line 6, 4-cycle diesel
Bore x Stroke	145mm x 183mm (5.7in x 7.2in)
Displacement	18.13 L (1106.3 in³)
Compression Ratio	14:1
Aspiration	Turbocharged Air-to-Air Aftercooled
Fuel Injection System	Electronic Unit Injection
Governor	Electronic ADEM™ A4

Model	Standby	Prime	Emission Strategy
DE850E0	850 kVA	770 kVA	Low BSFC

PACKAGE PERFORMANCE

Performance	Standby	Prime
Frequency	50 Hz	
Genset Power Rating	850 kVA	770 kVA
Genset power rating with fan @ 0.8 power factor	680 ekW	616 ekW
Emissions	Low BSFC	
Performance Number	EM3830	EM3831
Fuel Consumption		
100% load with fan, L/hr (gal/hr)	180 (47.6)	162 (42.8)
75% load with fan, L/hr (gal/hr)	132 (34.9)	118 (31.2)
50% load with fan, L/hr (gal/hr)	87 (23)	80 (21.1)
25% load with fan, L/hr (gal/hr)	47 (12.4)	44 (11.6)
Cooling System¹		
Radiator air flow restriction (system), kPa (in. Water)	0.12 (0.48)	0.12 (0.48)
Radiator air flow, m³/min (cfm)	852 (30088)	852 (30088)
Engine coolant capacity, L (gal)	21 (5.5)	21 (5.5)
Radiator coolant capacity, L (gal)	89 (23.5)	89 (23.5)
Total coolant capacity, L (gal)	110 (29.1)	110 (29.1)
Inlet Air		
Combustion air inlet flow rate, m³/min (cfm)	62 (2190)	58 (2048)
Max. Allowable Combustion Air Inlet Temp, °C (°F)	NA	
Exhaust System		
Exhaust stack gas temperature, °C (°F)	410 (770)	400 (752)
Exhaust gas flow rate, m³/min (cfm)	142 (5015)	132 (4662)
Exhaust system backpressure (maximum allowable) kPa (in. water)	8.5 (2.5)	8.5 (2.5)
Heat Rejection		
Heat rejection to jacket water, kW (Btu/min)	205 (11658)	186 (10578)
Heat rejection to exhaust (total) kW (Btu/min)	659 (37477)	585 (33268)
Heat rejection to aftercooler, kW (Btu/min)	230 (13080)	209 (11886)
Heat rejection to atmosphere from engine, kW (Btu/min)	107 (6085)	98 (5573)

Emissions (Nominal) ²	Standby	Prime
NO _x , mg/Nm ³ (g/hp-hr)	2544.5 (5.57)	2547.5 (5.57)
CO, mg/Nm ³ (g/hp-hr)	535.1 (1.17)	268.3 (0.58)
HC, mg/Nm ³ (g/hp-hr)	35.1 (0.09)	14.0 (0.04)
PM, mg/Nm ³ (g/hp-hr)	36.0 (0.09)	19.4 (0.05)

Alternator ³						
Voltages	415 V	400 V	380 V	415 V	400 V	380 V
Motor starting capability @ 30% Voltage Dip & 0.6 P.F	2268 skVA	2118 skVA	1924 skVA	2268 skVA	2118 skVA	1924 skVA
Current	1182.5 amps	1227 amps	1291.4 amps	1071.2 amps	1111.4 amps	1170 amps
Frame Size	LC7224L	LC7224L	LC7224L	LC7224L	LC7224L	LC7224L
Excitation	AREP	AREP	AREP	AREP	AREP	AREP
Temperature Rise	150°C	150°C	150°C	125°C	125°C	125°C

WEIGHTS & DIMENSIONS

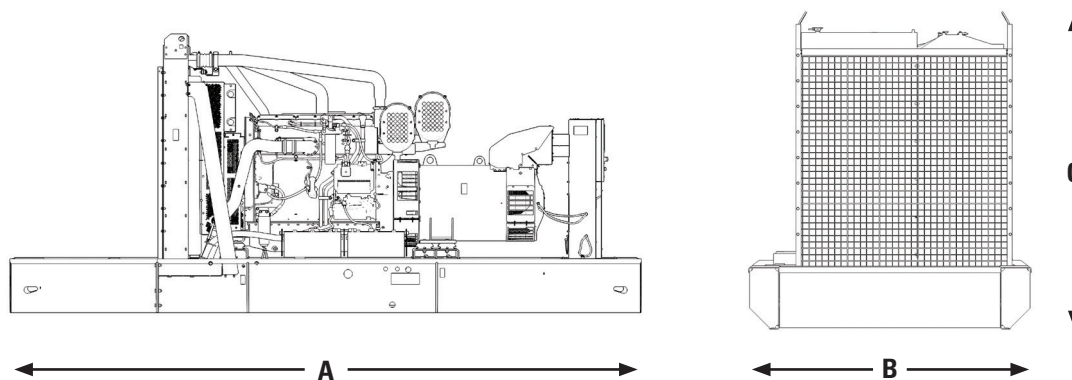

Dim "A" mm (in)	Dim "B" mm (in)	Dim "C" mm (in)	Dry Weight kg (lb)
4130 (163)	1689 (67)	2570 (101)	4532 (9991)

APPLICABLE CODES AND STANDARDS:

AS1359, CSA C22.2 No100-04, UL142, UL489, UL869, UL2200, NFPA37, NFPA70, NFPA99, NFPA110, IBC, IEC60034-1, ISO3046, ISO8528, NEMA MG1-22, NEMA MG1-33, 2006/95/EC, 2006/42/EC, 2004/108/EC.

Note: Codes may not be available in all model configurations. Please consult your local Cat Dealer representative for availability.

STANDBY: Output available with varying load for the duration of the interruption of the normal source power. Average power output is 70% of the standby power rating. Typical operation is 200 hours per year, with maximum expected usage of 500 hours per year.

PRIME: Output available with varying load for an unlimited time. Average power output is 70% of the prime power rating. Typical peak demand is 100% of prime rated kW with 10% overload capability for emergency use for a maximum of 1 hour in 12. Overload operation cannot exceed 25 hours per year.

RATINGS: Ratings are based on SAE J1349 standard conditions. These ratings also apply at ISO3046 standard conditions.

DEFINITIONS AND CONDITIONS

¹ For ambient and altitude capabilities consult your Cat dealer. Air flow restriction (system) is added to existing restriction from factory.

² Emissions data measurement procedures are consistent with those described in EPA CFR 40 Part 89, Subpart D & E and ISO8178-1 for measuring HC, CO, PM, NO_x. Data shown is based on steady state operating conditions of 77° F, 28.42 in HG and number 2 diesel fuel with 35° API and LHV of 18,390 BTU/lb. The nominal emissions data shown is subject to instrumentation, measurement, facility and engine to engine variations. Emissions data is based on 100% load and thus cannot be used to compare to EPA regulations which use values based on a weighted cycle.

³ UL 2200 Listed packages may have oversized generators with a different temperature rise and motor starting characteristics. Generator temperature rise is based on a 40° C ambient per NEMA MG1-32.

LET'S DO THE WORK.™

LEHE1817-03 (05/20)

www.Cat.com/electricpower
All rights reserved.

Materials and specifications are subject to change without notice. The International System of Units (SI) is used in this publication. © 2020 Caterpillar. All Rights Reserved. CAT, CATERPILLAR, LET'S DO THE WORK, their respective logos, "Caterpillar Corporate Yellow", the "Power Edge" and Cat "Modern Hex" trade dress as well as corporate and product identity used herein, are trademarks of Caterpillar and may not be used without permission.